



This unique face-mounted operator provides smooth, continuous control of casement and single vent awning windows. The dyad, or two-linked design, provides smooth operation of windows with both types of Truth Concealed Casement Hinges (Product lines #14 & #34). The detachable clip linkage allows this operator to be disengaged from the sash for easy assembly and installation. Three-point mounting feature provides increased stability of operator on the window. Also available with two-point mounting for special window designs. See drawing for further details.

PRODUCT APPLICATION

ASSISTANCE: If you are designing a new window profile, or are having difficulty selecting hardware for your window, please contact Truth. Our highly trained Product Specialists can assist you with the selection of the appropriate hardware to meet your performance requirements, as well as providing personalized application drawings.

LOGO OPTIONS: Have you considered *personalizing* your window with your company name or logo? All of Truth’s operator handles are capable of accepting your own “signature”. Contact Truth for further details.

WARRANTY:

Protected under the terms of the Truth Warranty for Window and Door Manufacturers and Authorized Distributors. Refer to Truth’s Terms and Conditions for further details.

CORROSION PROTECTION:

Truth’s E-Gard® Hardware has a multi-stage coating process that produces a superior physical and aesthetic finish. Plus, it is resistant to a wider range of corrosive materials, including industrial cleaning materials and environmental pollutants. This proprietary process has been tested to be approximately three times better than common zinc plated finishes.

For the severe conditions associated with coastal areas, Truth has developed certain product lines utilizing either **CoastGard® Hardware**, or stainless steel hardware. See Tech Note #7 for further information about corrosion protection and these special hardware options



MATERIAL: High-pressure die-cast zinc case, crank handle and knob. Hardened steel worm and gear.

FINISH: Electrostatically applied, durable coatings that provide excellent resistance to chipping, scratching and corrosion while maintaining color stability for years in direct sunlight. Please refer to Truth’s Color Chart for examples of Truth’s most popular finish options. Truth also offers a wide range of decorative “plated” finishes - contact Truth for additional information on availability of these finishes on specific product lines.

ORDERING INFORMATION:

1. Choose Dyad Operator style desired (specify by part number).
2. Specify finish number.
3. Specify left- or right-hand (determined by the side the hinge is on when viewed from the inside).
4. Select mounting hardware (sold separately):
 #11454 - Contour Handle (painted) or #10579 - Roto Gear Operator Handle - shown above (painted).
Optional handle styles, such as Truth’s *Folding Handle*, are also available.
Handed Stud Brackets - select from the tables in the following drawings. Optional brackets for special profile applications available - see Brackets & Track Section.
5. Optional mounting hardware (sold separately).
 #20947 - Backing Plates (2 per operator).
 #30591 - Detach clip (included with the operator - replacement pieces sold separately).

- #30812 - Rubber cork adhesive backed gasket (for 2-point mounting).
- #21306 - Protective red plastic spline cap (optional).

RECOMMENDED SCREWS:

Types of screws required determined by material of profile used. Refer to drawings for complete information on screw type and quantity needed (sold separately). For additional information regarding screw selection - see Truth Tips and Tech Note #11.

TRUTH TIPS:

1. Before selecting an operator, the hinge should be selected depending upon desired window features and hinge requirements (example: egress vs. washability).
2. Operator and Stud Bracket handing is determined by the hinge side when viewed from the inside (commercially handed).
3. The Truth Dyad Operator should not be used with Egress style or Butt Hinges.
4. The Dyad Operator is not recommended for windows with stiff, slide by weatherstrip. To insure proper operation and long operator life, weatherstrip forces should be minimized. To find out if the weatherstrip forces are acceptable, the following procedure is suggested:
 A) From a complete window package, disconnect the operator so that the sash opens and closes freely B) Mount window plumb and square.

TRUTH TIPS (con't):

C) Connect spring scale or other force measuring device to lower lock side of the sash and measure the force required to completely close the window through its final one inch of travel.

D) Multiply the force from Step C by the sash width and divide by dimension "A" from Figure 1. For acceptable performance, this calculated force must be less than 150 lbs. If your window exceeds the forces as measured by the procedure outlined above, Truth recommends that the Dyad Operator *not* be used.

5. To insure the proper selection of window hardware and mounting locations that will provide the best operating results, please follow these simple steps:

REFER TO FIGURE 1. A) Determine the space available for operator arm clearance in the closed position - see 1.438" (33.3 mm) minimum dimension-center drawing. B) Choose a Stud Bracket that will best fit the profile and will maximize the "A" dimension. C) Choose an operator that is compatible with the bracket chosen in Step B. D) Once the operator is determined, check the elevation of the operator with respect to the hinge to insure the elevation of the operator does not fall below the stated minimums.

6. The "C" dimension taken from the tables shown, with each individual operator, should be used as the starting point for determining operator location relative to the bracket location. In most cases, this will be the correct location. If while closing the window, the operator arm comes in contact with the sash, then shift the operator away from the hinge side of the window. If the window will not come completely closed, and the operator has reached it's fully closed position, then shift the operator towards the hinge side of the window.

7. Mounting Screws must pass through two PVC walls, or one PVC wall and one insert wall or one PVC wall and Truth Backing Plates (#20947). For this reason, it may be necessary to use a longer screw than is recommended.

8. For metal window profiles, Truth recommends machine screws. However, in most applications, sheet metal screws will provide adequate holding power.

9. A Spline Cap (#21306) is available to protect the operator splines from dirt and other windows from damage during shipping, installation, and final building construction.

10. Truth Stud Brackets shown in Figure 8 through Figure 12 will fit the majority of the profiles. In the event that the Stud Brackets shown will not satisfactorily fit a profile, other specialized Stud Brackets are available - see Brackets & Track Section.

11. Sash weight should be limited to 50 lbs. to insure ease of operation for the lifetime of the window. When used on a sash weighing over 50 lbs., operating effort will increase and operator life will be reduced.

12. When a Dyad Operator is installed in windows used in high rise applications over two stories, a Truth Limit Device, to restrict the amount of opening, may be necessary. Contact Truth for wind loading information.

13. For accurate hardware placement in vinyl or metal applications, pre-drilling is recommended.

14. Truth recommends that a Snubber be used at the center of the hinge side on any casement window which has a tendency to bow outwardly at the center in the closed position. Adding a Snubber may increase the negative air pressure rating of the window.

15. When selecting mounting screws for Truth hardware, coating compatibility is one of the most important criteria. For best corrosion resistance the coating on the screws should be the same as the coating on the hardware. For more information see Tech Note #11.

INCLUDE TRUTH SPECS ON YOUR NEXT WINDOW PROJECT

Window operators shall be provided which allow easy adjustment of window position. The mechanism should be crank operated and provide smooth operation out to 90° of sash opening. Connection to the movable sash must be easily detachable for window cleaning and maintenance.

Window operators will be of drag arm/link design driven by a hand crank. The operator must be constructed of E-Gard® components, hardened steel worm and gearing and high pressure zinc alloy die cast housing.

Window Operators shall be 23 series Dyad Operator as manufactured by Truth Hardware, Owatonna, MN

FIG. 1 APPLICATION OF 23 SERIES DYAD OPERATOR

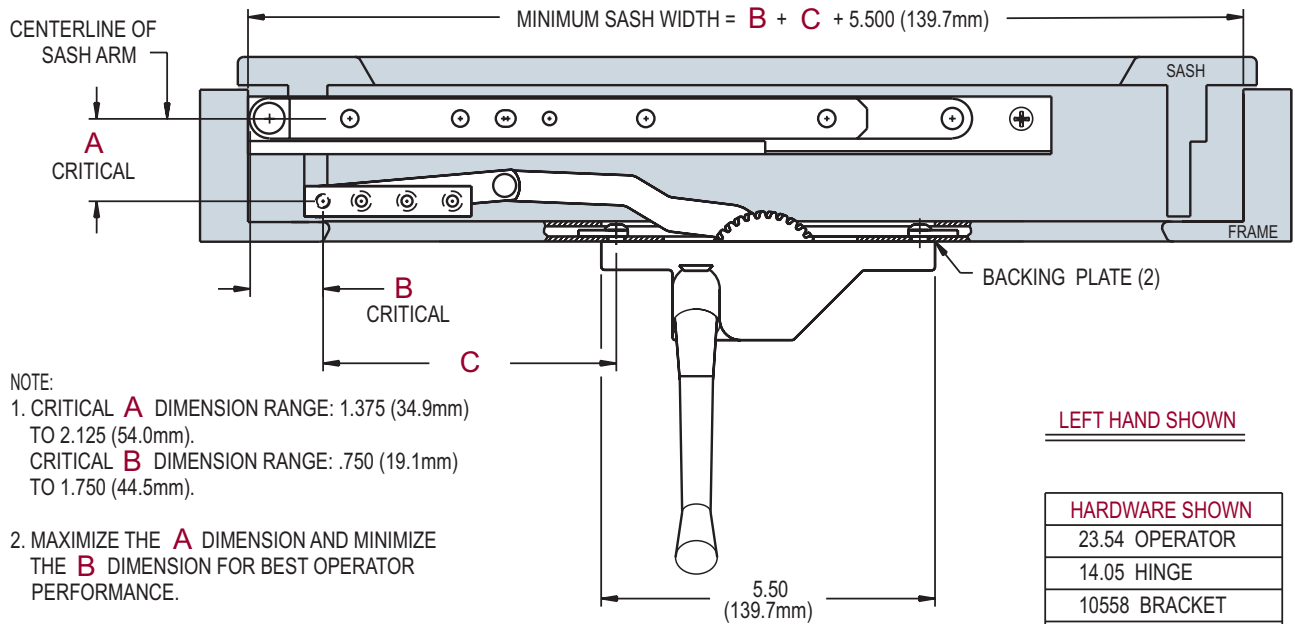

NOTE:

1. CRITICAL **A** DIMENSION RANGE: 1.375 (34.9mm) TO 2.125 (54.0mm).
CRITICAL **B** DIMENSION RANGE: .750 (19.1mm) TO 1.750 (44.5mm).
2. MAXIMIZE THE **A** DIMENSION AND MINIMIZE THE **B** DIMENSION FOR BEST OPERATOR PERFORMANCE.
3. CONTACT TRUTH IF YOUR PROFILES DO NOT FIT THE RECOMMENDED **A** AND **B** DIMENSION RANGES.
4. SEE OPERATOR AND HINGE COMPATABILITY CHART IN FIG.2 BEFORE SELECTING OPERATOR FOR YOUR APPLICATION.
5. TO DETERMINE MTG LOCATION OF BRACKETS ADD OR SUBTRACT DIMENSION **L** AND **F**.

LEFT HAND SHOWN

HARDWARE SHOWN
23.54 OPERATOR
14.05 HINGE
10558 BRACKET
10579 HANDLE
20947 BACKING PLATE (2)

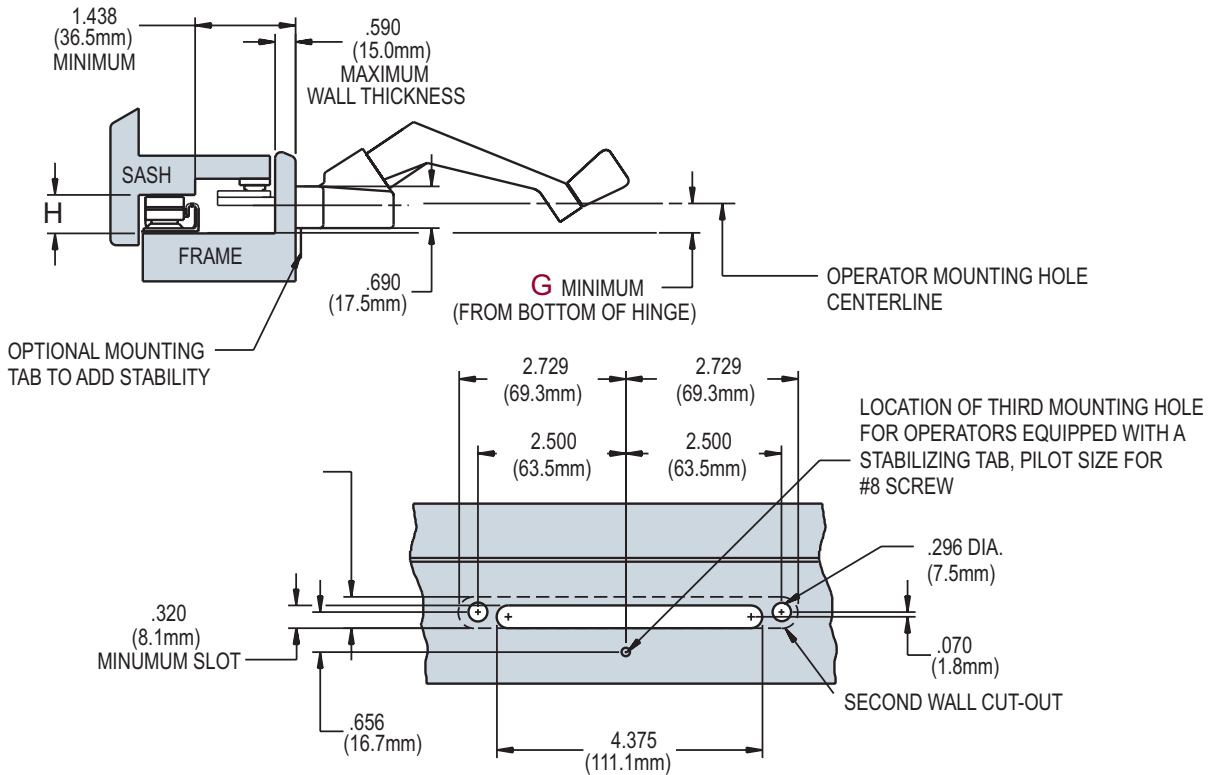

FIG. 2 DYAD OPERATOR

OPERATOR/HINGE COMPATABILITY TABLE							
HINGE STACK H	DESCRIPTION	HINGE PART NUMBER	TYPE OF HINGE	23.46 & 23.59	23.49	23.54 & 23.65	23.55 & 23.66
.438 (11.1mm)	CONCEALED CSMT HNG	14.75 & 14.05	2 BAR	X	X	O	O
	CONCEALED CSMT HNG	14.76 & 14.06	2 BAR	Z	Z	Z	Z
	CONCEALED CSMT HNG	14.80	2 BAR	X	X	O	O
.500 (12.7mm)	201 8"	34.10 NO STOP	4 BAR	O	O	-	-
	201 10"	34.11 NO STOP	4 BAR	Z	Z	X	X
	201 12"	34.12 NO STOP	4 BAR	Z	Z	X	X
	401 90° 12"	34.55	4 BAR	Z	Z	X	X
	401 90° 14"	34.56	4 BAR	Z	Z	X	X
	401 90° 16"	34.57	4 BAR	Z	Z	X	X
.531 (13.5mm)	401 90° SD 12"	** 34.81	4 BAR	X	X	O	O
.625 (15.9mm)	301 10"	34.24 NO STOP	4 BAR	Z	Z	X	X
	301 12"	34.25 NO STOP	4 BAR	Z	Z	Z	Z
	601 90° 14"	34.59	4 BAR	Z	Z	X	X
	601 90° 16"	34.60	4 BAR	Z	Z	X	X
	601 90° 18"	34.61	4 BAR	Z	Z	X	X

X = RECOMMENDED FOR BEST PERFORMANCE

O = RECOMMENDED, HOWEVER OPERATOR TORQUE MAY BE SLIGHTLY HIGHER AND OPERATOR MAY FIT INTO NARROWER SASH OPENING THAN SPECIFIED.

Z = RECOMMENDED, HOWEVER OPERATOR WILL ONLY OPEN SASH TO APPROXIMATELY 80%-90% OF FULL OPENING.

** BLACK ACETAL SHOE

NOTE: ALUMINUM HINGES ARE NOT RECOMMENDED FOR CASEMENT APPLICATIONS

FIG. 3 23.46 and 23.59 DYAD OPERATOR (23.59 has stability tab)

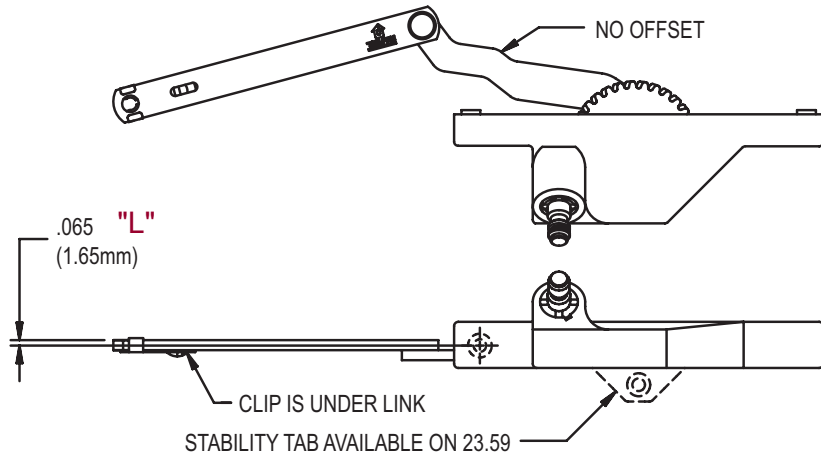

LEFT HAND SHOWN

AVAILABLE BRACKETS	
LH	RH
10494	10495
*10558	

*RECOMMENDED

C = 5.425 (137.8mm)

HINGE STACK H (SEE NOTE 1)	G MINIMUM
.438 (11.1mm)	.622 (15.8mm)
.500 (12.7mm)	.671 (17.0mm)
.532 (13.5mm)	.702 (17.8mm)
.625 (15.9mm)	.761 (19.3mm)

RECOMMENDED SCREWS:

2 (P/N 19535.XX) #8 - 32 X .312 PHILLIPS, TRUSS HEAD, MACHINE SCREWS

1 (P/N 19218.XX) #8 X .750 PHILLIPS, FLAT HEAD, SHEET METAL SCREWS (STABILITY TAB)

NOTE:

1. CHECK THE OPERATOR/HINGE COMPATABILITY TABLES TO VERIFY THAT A PARTICULAR OPERATOR WILL WORK WITH A PARTICULAR HINGE (SEE FIG. 2)

FIG. 4 2.49 DYAD OPERATOR

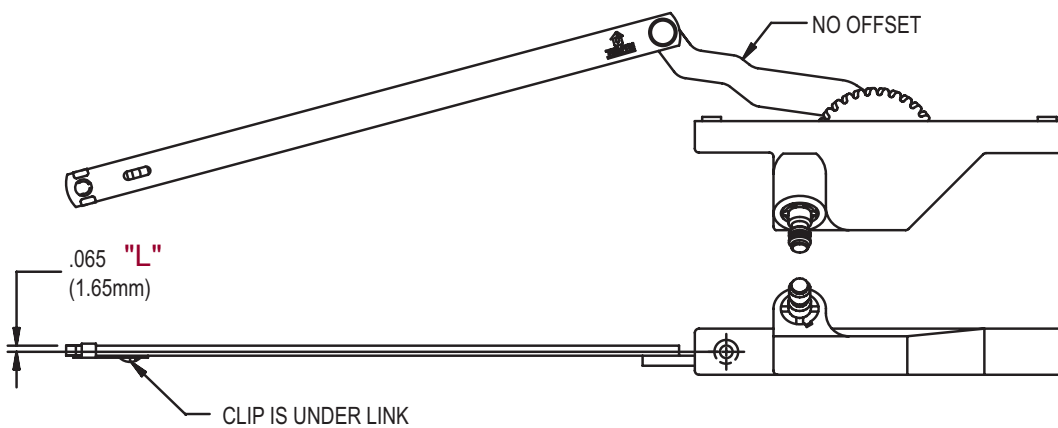

LEFT HAND SHOWN

AVAILABLE BRACKETS	
LH	RH
10494	10495
*10558	

*RECOMMENDED

C = 9.600 (243.9mm)

HINGE STACK H (SEE NOTE 1)	G MINIMUM
.438 (11.1mm)	.622 (15.8mm)
.500 (12.7mm)	.671 (17.0mm)
.532 (13.5mm)	.702 (17.8mm)
.625 (15.9mm)	.761 (19.3mm)

RECOMMENDED SCREWS:

WOOD: 2 (P/N 19535.XX) #8 - 32 X .312 PHILLIPS, TRUSS HEAD, MACHINE SCREWS

NOTE:

1. CHECK THE OPERATOR/HINGE COMPATABILITY TABLES TO VERIFY THAT A PARTICULAR OPERATOR WILL WORK WITH A PARTICULAR HINGE (SEE FIG. 2)

FIG. 5 23.54 and 23.65 DYAD OPERATOR (23.65 has stability tab)

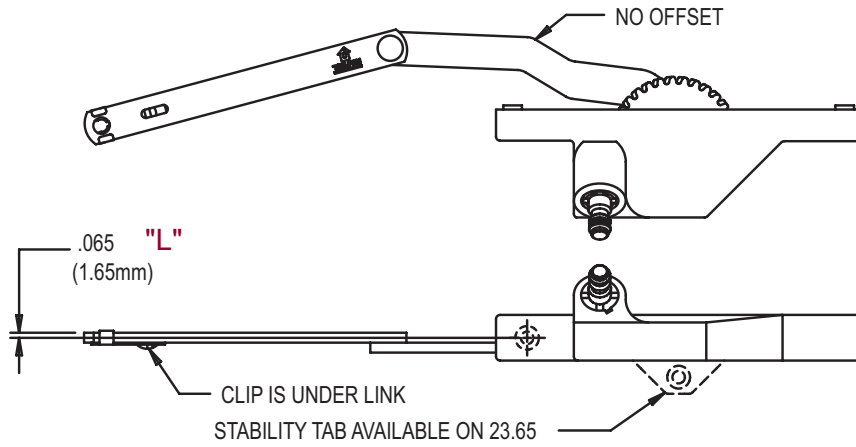

LEFT HAND SHOWN

AVAILABLE BRACKETS	
LH	RH
10494	10495
*10558	

*RECOMMENDED

C = 6.300 (160.0mm)

RECOMMENDED SCREWS:

2 (P/N 19535.XX) #8 - 32 X .312 PHILLIPS, TRUSS HEAD, MACHINE SCREWS

1 (P/N 19218.XX) #8 X .750 PHILLIPS, FLAT HEAD, SHEET METAL SCREWS
(THIRD MOUNTING POINT)

NOTE:

1. CHECK THE OPERATOR/HINGE COMPATABILITY TABLES TO VERIFY THAT A PARTICULAR OPERATOR WILL WORK WITH A PARTICULAR HINGE (SEE FIG. 2)

HINGE STACK H (SEE NOTE 1)	G MINIMUM
.438 (11.1mm)	.622 (15.8mm)
.500 (12.7mm)	.671 (17.0mm)
.532 (13.5mm)	.702 (17.8mm)
.625 (15.9mm)	.761 (19.3mm)

FIG. 6 23.66 DYAD OPERATOR

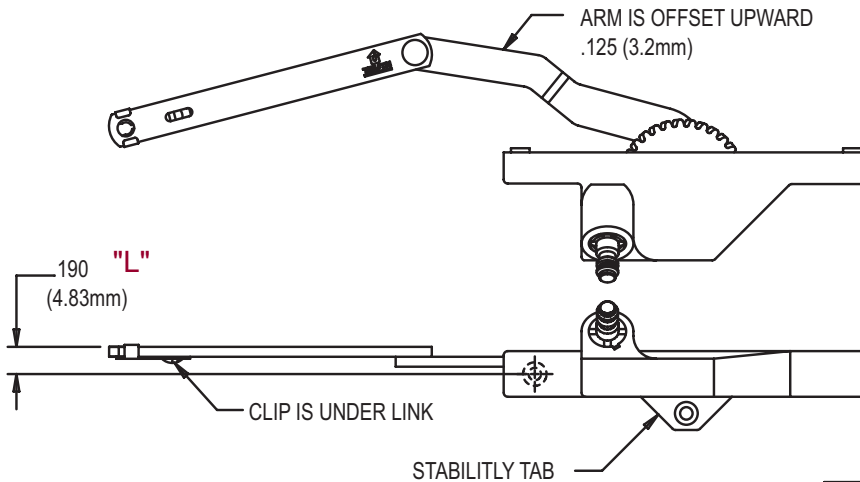

LEFT HAND SHOWN

AVAILABLE BRACKETS	
LH	RH
10494	10495
*10558	

*RECOMMENDED

C = 6.260 (159.0mm)

RECOMMENDED SCREWS:

2 (P/N 19535.XX) #8 - 32 X .312 PHILLIPS, TRUSS HEAD, MACHINE SCREWS

1 (P/N 19218.XX) #8 X .750 PHILLIPS, FLAT HEAD, SHEET METAL SCREWS
(THIRD MOUNTING POINT)

NOTE:

1. CHECK THE OPERATOR/HINGE COMPATABILITY TABLES TO VERIFY THAT A PARTICULAR OPERATOR WILL WORK WITH A PARTICULAR HINGE (SEE FIG. 2)

HINGE STACK H (SEE NOTE 1)	G MINIMUM
.438 (11.1mm)	.537 (13.6mm)
.500 (12.7mm)	.586 (14.9mm)
.532 (13.5mm)	.617 (15.7mm)
.625 (15.9mm)	.676 (17.2mm)

FIG. 7 STUD BRACKETS 11253.XX, 11254.XX

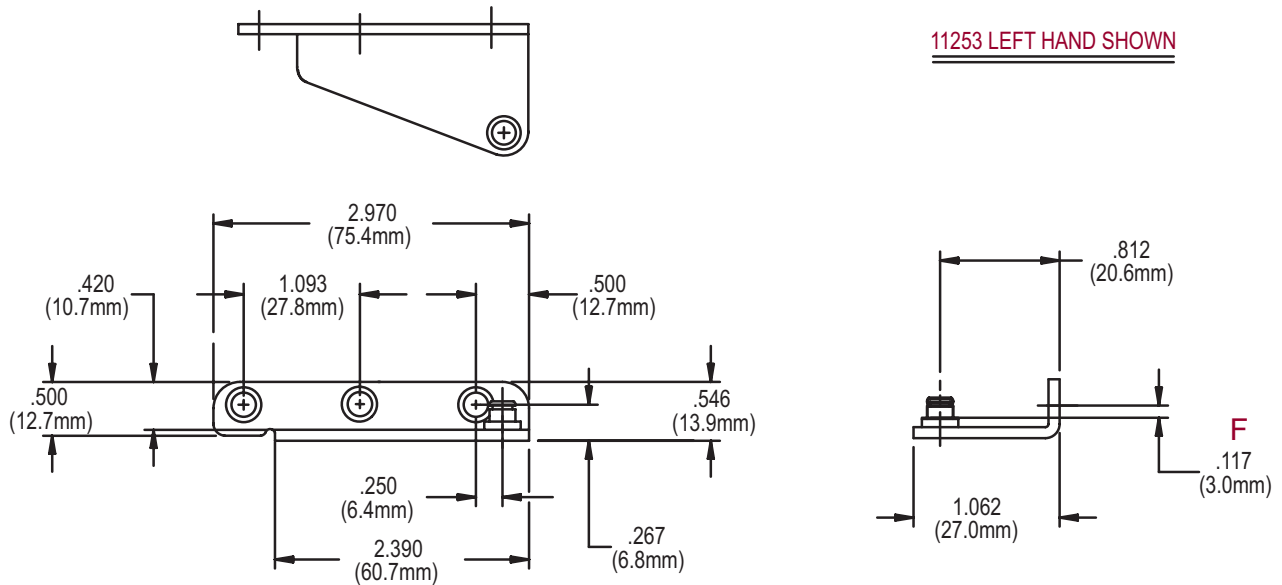

11253 LEFT HAND SHOWN

RECOMMENDED SCREWS:

WOOD: 3 (P/N 19260.XX) #8 X 1.25 PHILLIPS, FLAT HEAD, SHEET METAL SCREWS

PVC & METAL: 3 - #8 PHILLIPS, FLAT HEAD SCREWS (LENGTH AND THREAD TYPE DETERMINED BY PROFILE)

NOTE: 11254 RIGHT HAND

FIG. 8 STUD BRACKETS 10917.XX, 10918.XX

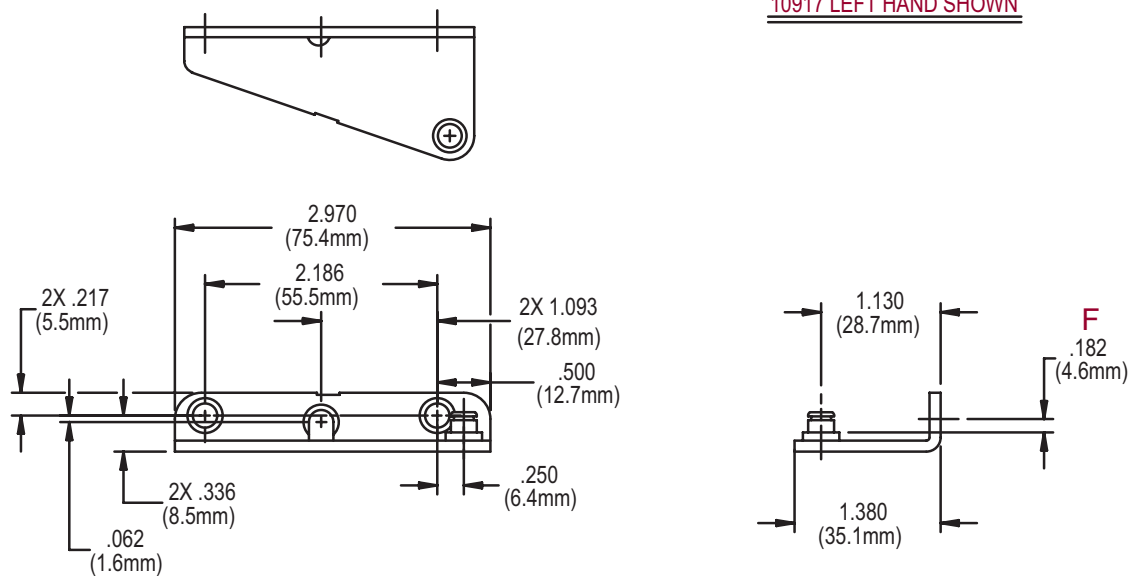

10917 LEFT HAND SHOWN

RECOMMENDED SCREWS:

WOOD: 3 (P/N 19260.XX) #8 X 1.25 PHILLIPS, FLAT HEAD, SHEET METAL SCREWS

PVC & METAL: 3 - #8 PHILLIPS, FLAT HEAD SCREWS (LENGTH AND THREAD TYPE DETERMINED BY PROFILE)

NOTE: 10918 RIGHT HAND

FIG. 9 STUD BRACKETS 10558.XX

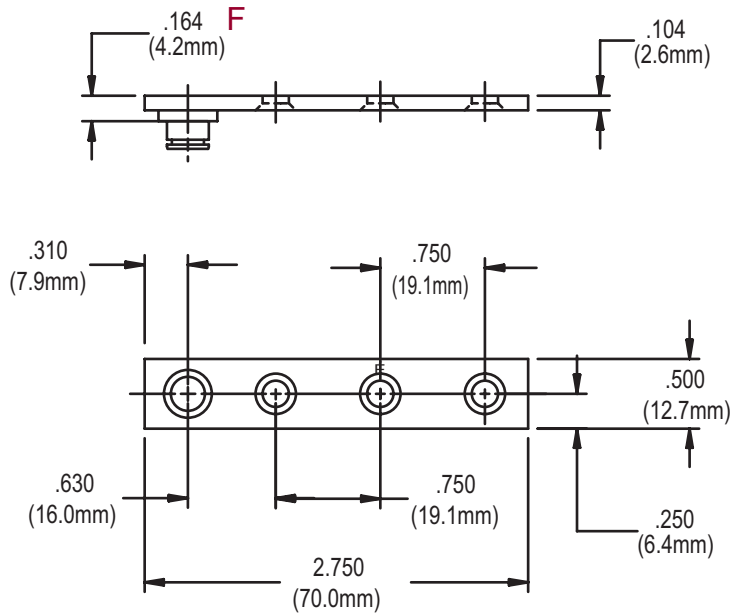

NON HANDED

RECOMMENDED SCREWS:

WOOD: 3 (P/N 19140.XX) #7 X .875 PHILLIPS, FLAT HEAD, SHEET METAL SCREWS

PVC & METAL: 2 - #7 PHILLIPS, FLAT HEAD SCREWS (LENGTH AND THREAD TYPE DETERMINED BY PROFILE)

FIG. 10 STUD BRACKETS 10456.XX, 10457.XX

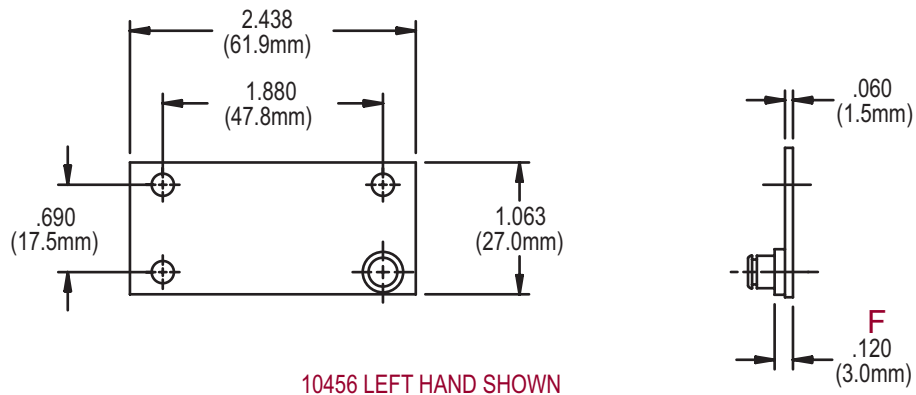

10456 LEFT HAND SHOWN

RECOMMENDED SCREWS:

WOOD: 3 (P/N 19355.XX) #10 X .750 PHILLIPS, PAN HEAD, SHEET METAL SCREWS

PVC & METAL: 3 - #10 PHILLIPS, PAN HEAD SCREWS (LENGTH AND THREAD TYPE DETERMINED BY PROFILE)

NOTE: 10457 RIGHT HAND

FIG. 11 STUD BRACKETS 10494.XX, 10495.XX

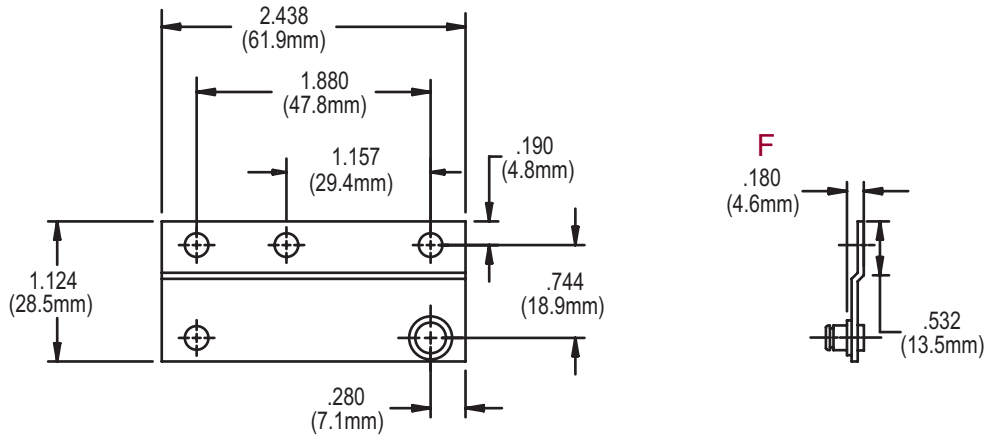

RECOMMENDED SCREWS:

10494 LEFT HAND SHOWN

WOOD: 2 (P/N 19355.XX) #10 X .750 PHILLIPS, PAN HEAD, SHEET METAL SCREWS

PVC & METAL: 2 - #10 PHILLIPS, PAN HEAD SCREWS (LENGTH AND THREAD TYPE DETERMINED BY PROFILE)

NOTE: 10495 RIGHT HAND

FIG. 12 GASKET 30812

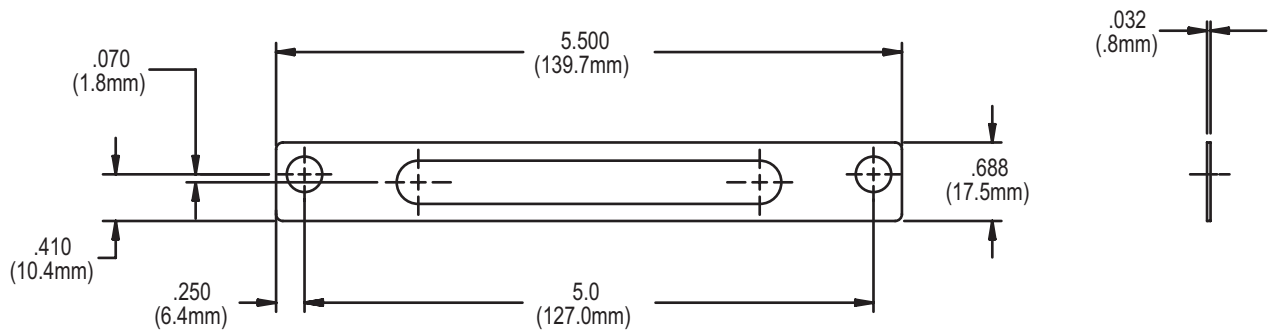
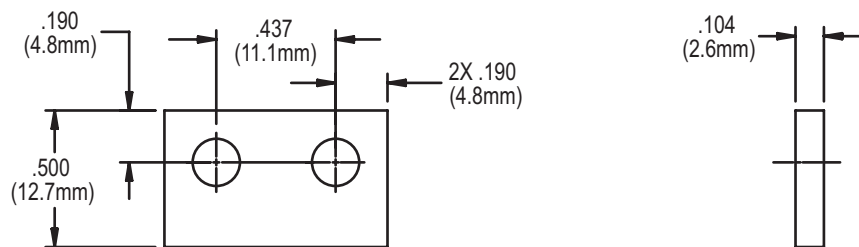

FIG. 13 BACKING PLATE 20947.XX



NOTE:

1. (2) BACKING PLATES REQUIRED PER OPERATOR
2. PLATE IS DESIGNED FOR A #8 SCREW TO PASS THROUGH IT FOR REAR MOUNT AND FOR A #10 SCREW TO TAP INTO IT FOR FRONT MOUNT.



700 WEST BRIDGE STREET, OWATONNA, MN 55060 ■ 507.451.5620 800.866.7884 ■ TRUTH.COM